

Plan View

10'

10'

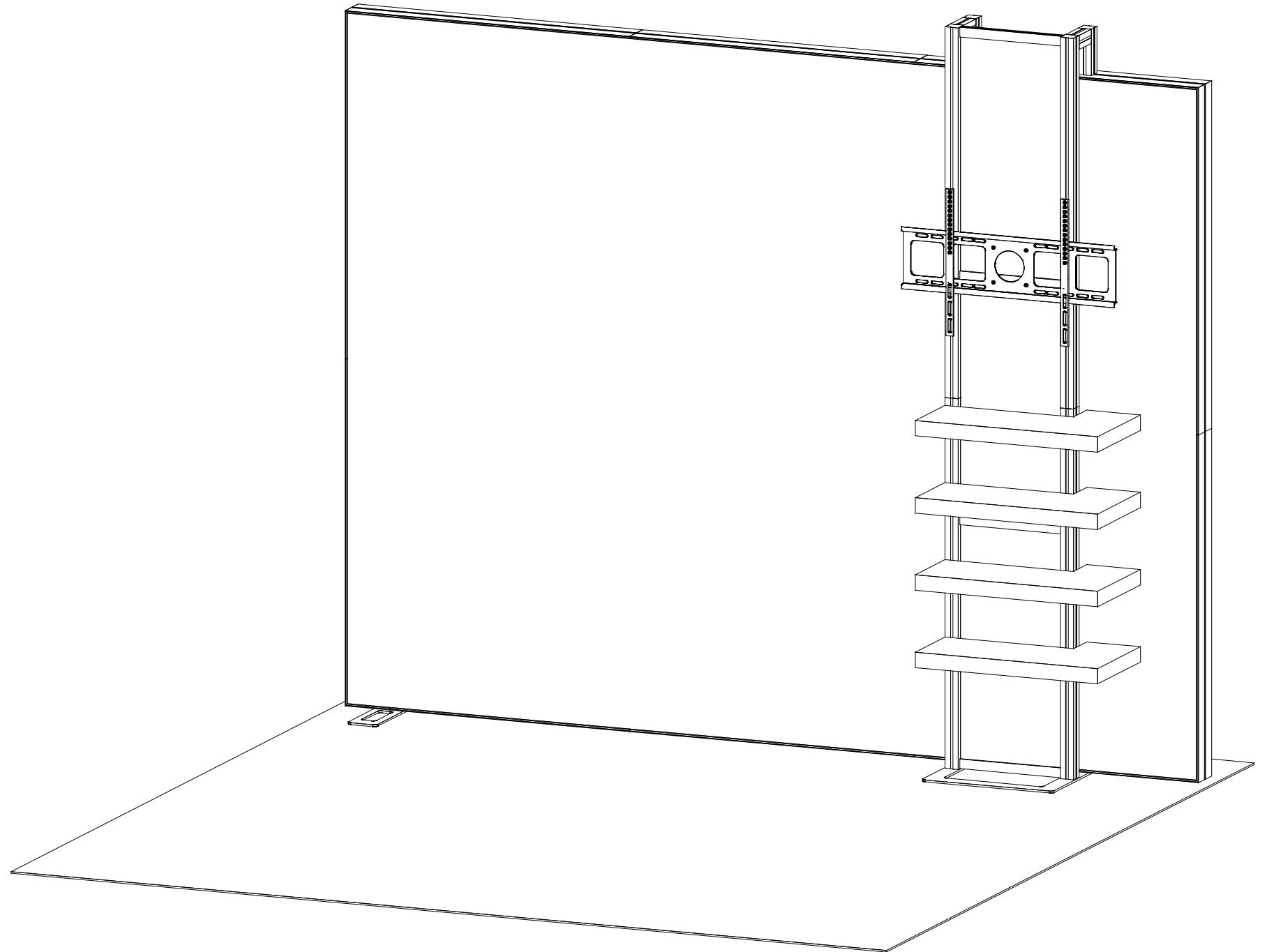

# ***SETUP INSTRUCTIONS***

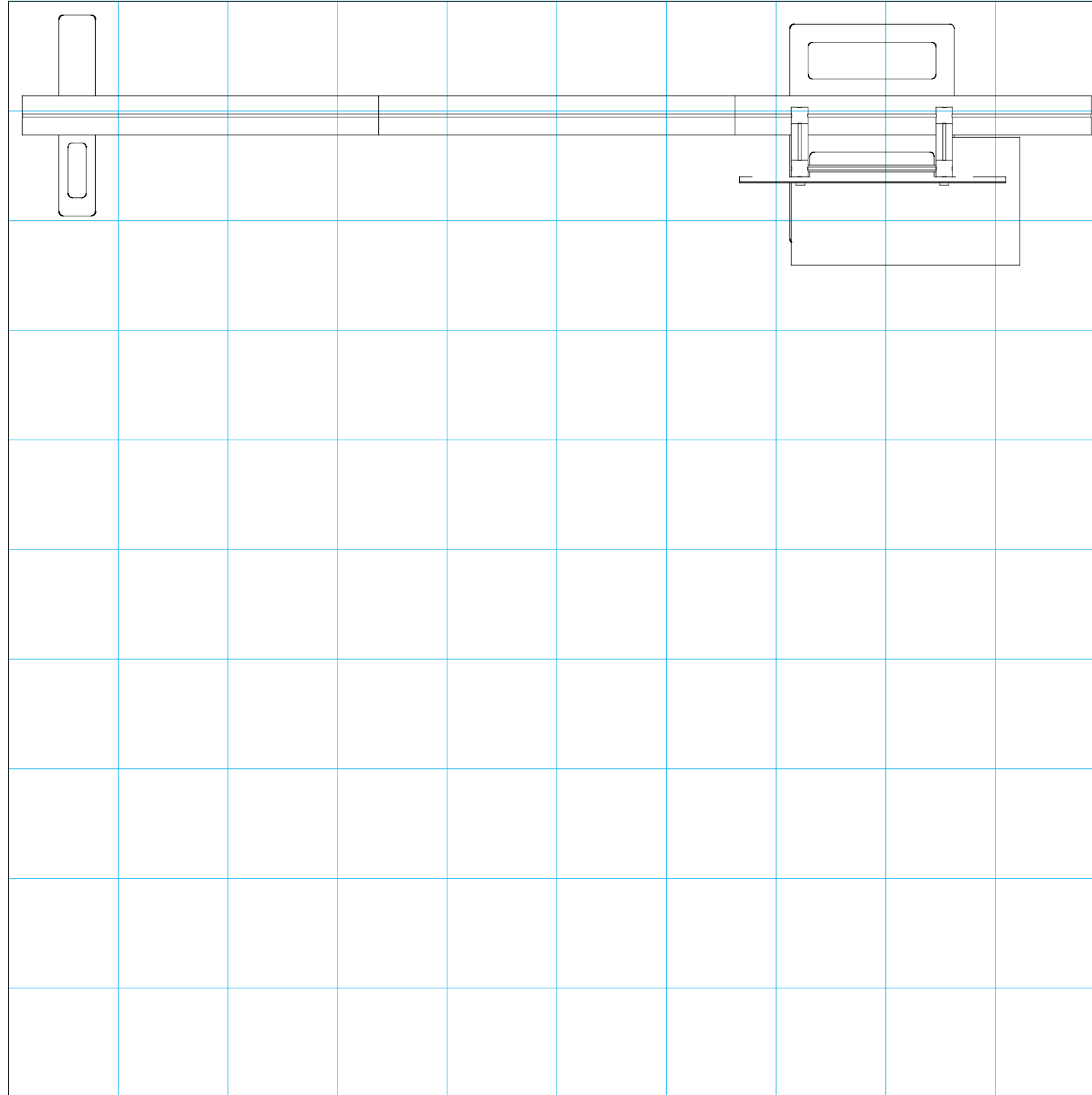

= 1 sq foot

## General Setup Instructions

- Read entire setup instruction manual prior to unpacking parts and pieces.
- The setup instructions are created specifically for this configuration.
- Setup instructions are laid out sequentially in steps, including exploded views with detailed explanation for assembly.

## Cleaning & Packing

- For Cleaning Metal, Plex, & Laminate Parts: Use a **MILD NON-ABRASIVE** cleanser and soft cloth/paper towel to clean all surfaces.
- Keep exhibit components away from heat and prolonged sun exposure. **Heat and UV exposure will warp and fade components.**
- Retain all provided Packing Materials. All provided packing materials are for ease of repacking & component protection.

## Disassembly

- For loss prevention, tighten all set screws and locks during disassembly.

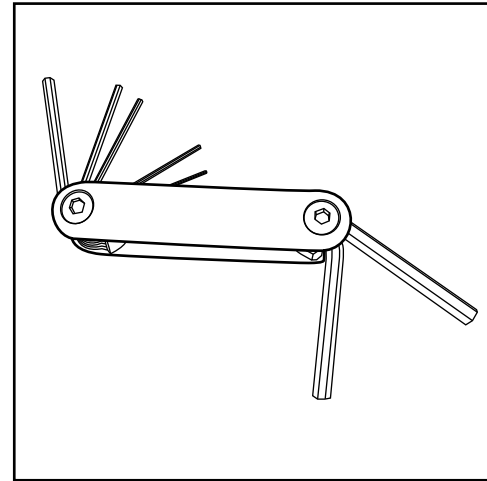

Hex Tool - Essential for Assembly

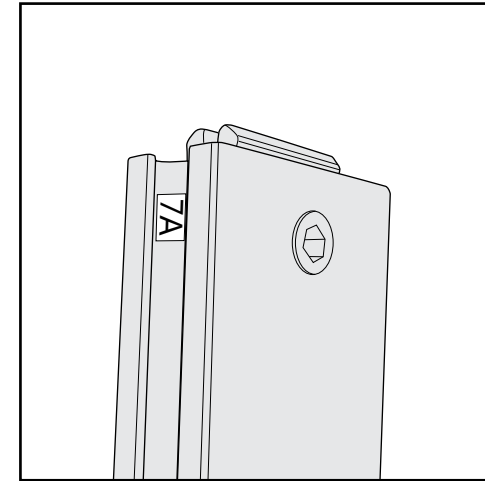

Part Identification - Numbering

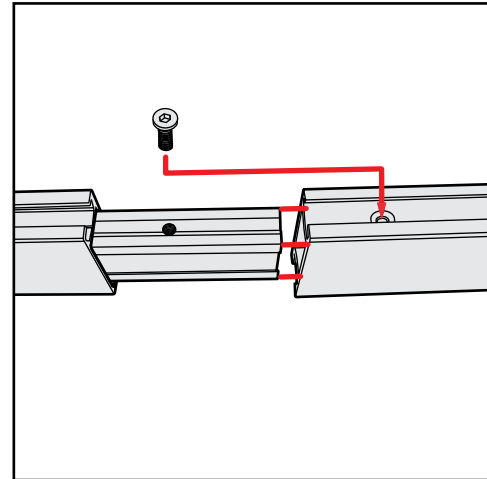

Spline Connection

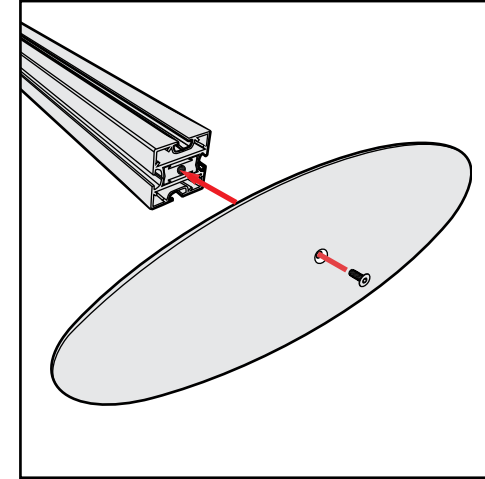

Base Plate & Extrusion Connection

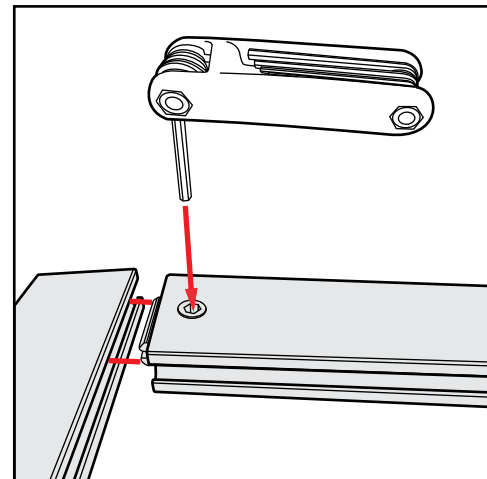

Extrusion & Lock Connection

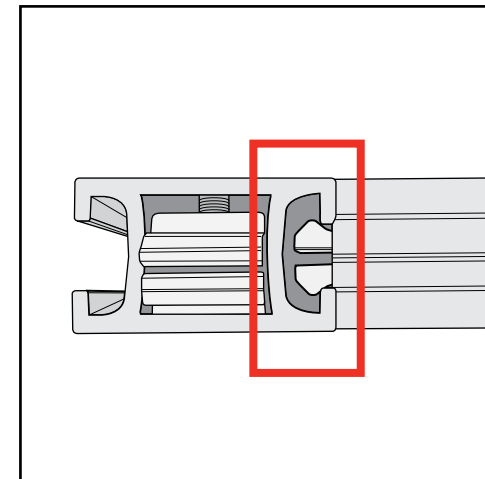

Engaged Lock



**WARNING**



DO NOT USE POWER TOOLS

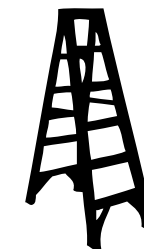

LADDERS OR LIFTS  
MAY BE REQUIRED



ALL CONNECTIONS MUST  
BE TIGHTLY SECURED

## Straight Connection

When assembling frame, first attach all **straight connectors**, then attach **corner connectors**.

- 1) Place extrusions end-to-end.
- 2) Loosen all knobs, then slide **straight connectors** across the seam of extrusions.
- 3) Tighten all knobs to secure connection.

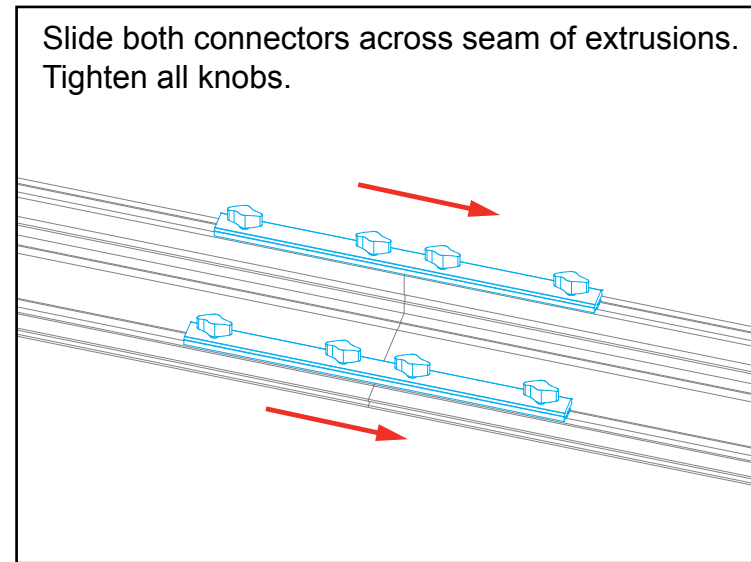
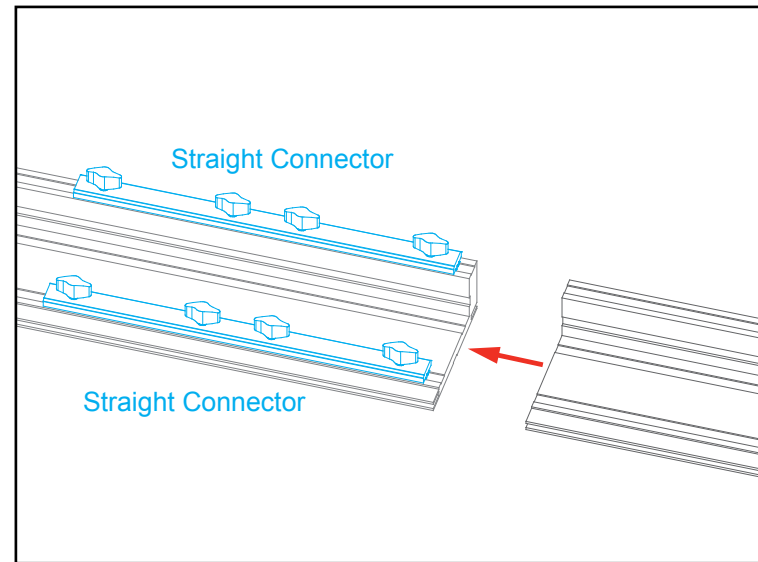

All knobs must be tightened securely to ensure a proper connection.

## Disassembly

- 1) Loosen all knobs.
- 2) Slide connectors off of one extrusion.
- 3) Tighten knobs to prevent loss during packing & shipping.

Keep straight connectors in groove of extrusion. Do not remove connectors during disassembly.

## Corner Connection

- 1) Loosen knobs, then slide vertical extrusions onto **corner connectors** of **lower** horizontal extrusion.
- 2) Slide **corner connectors** of **upper** horizontal extrusion into grooves of vertical extrusions.
- 3) Tighten all knobs to secure connection.

## Disassembly

- 1) Loosen knobs on vertical extrusions.
- 2) Slide the vertical extrusions off of **corner connectors** on lower and upper horizontal extrusions.

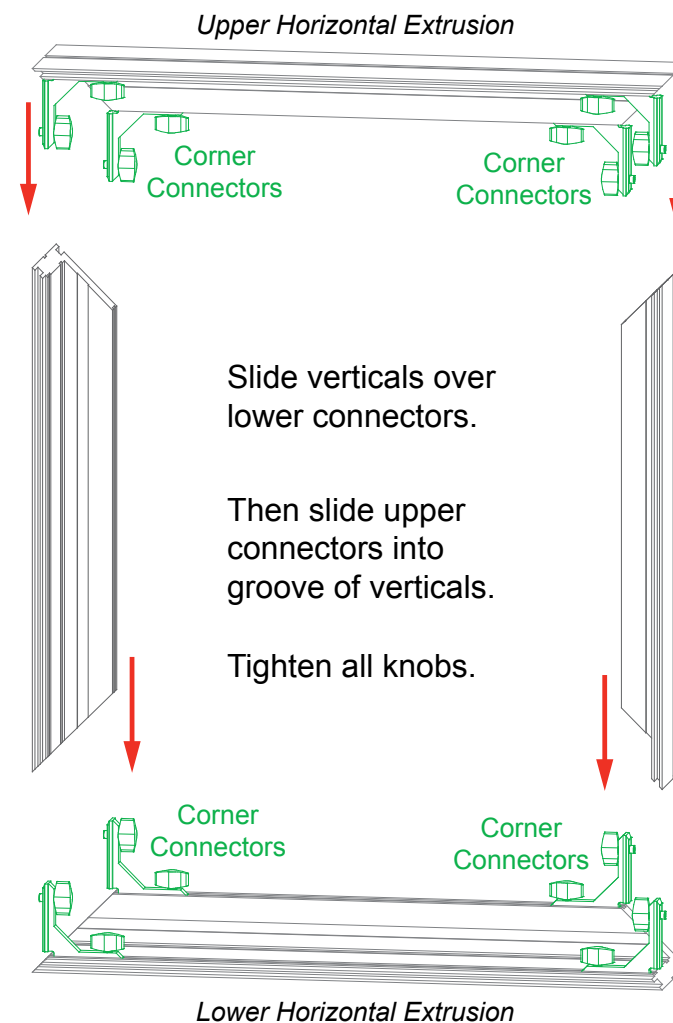

Adjust connectors if necessary to prevent gaps in connection.

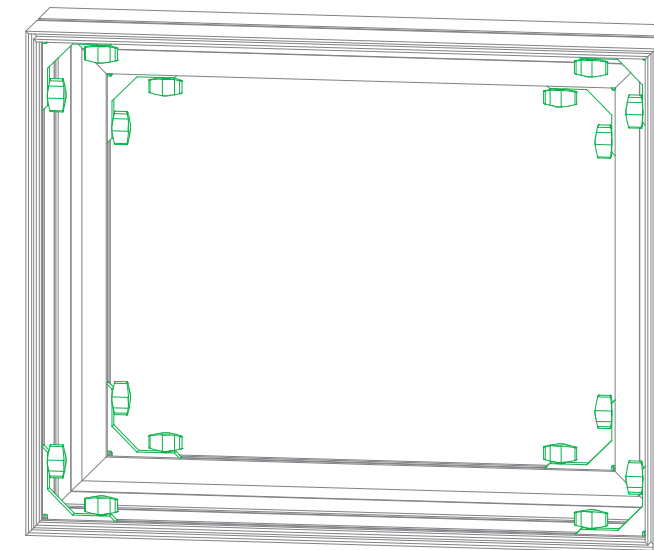

COMPLETED ASSEMBLY

All knobs must be tightened securely to ensure a proper connection.

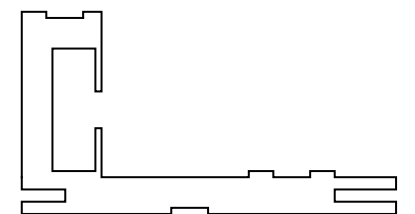

CEI110 Profile

# The Perfect Fit

## SEG Graphic Installation in 3 Steps

### STEP 1: Attach Corners

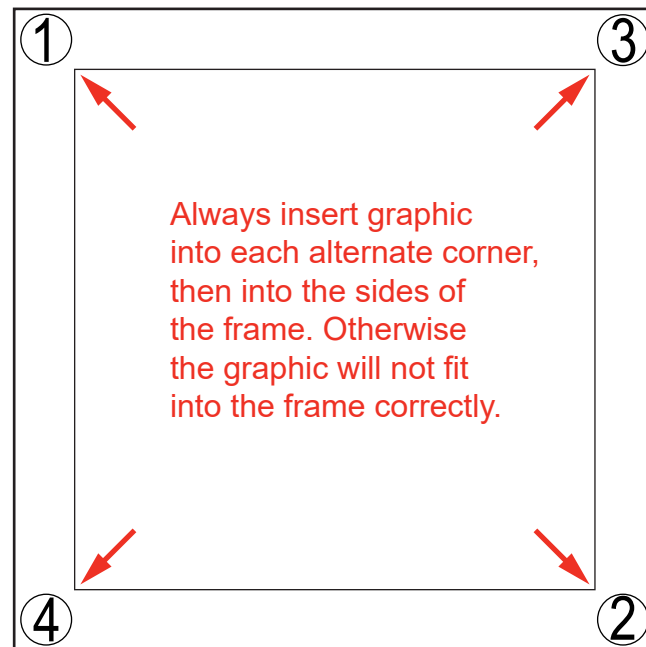

### STEP 2: Attach Middle

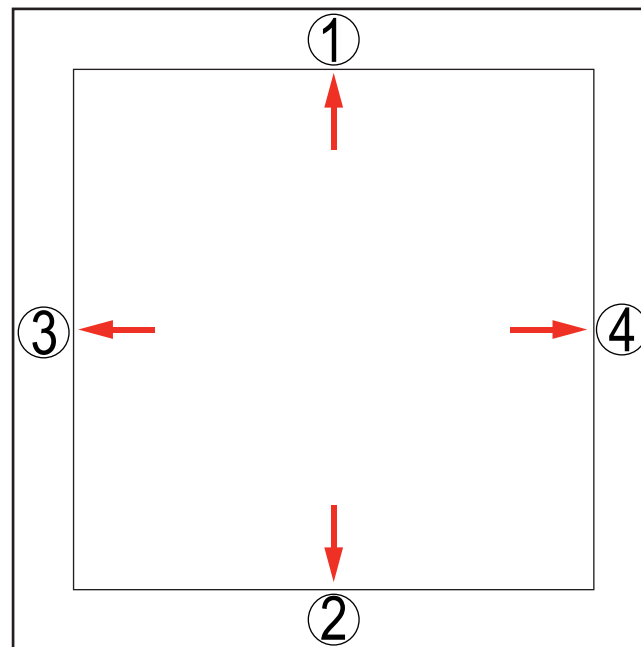

### STEP 3: Attach Sides

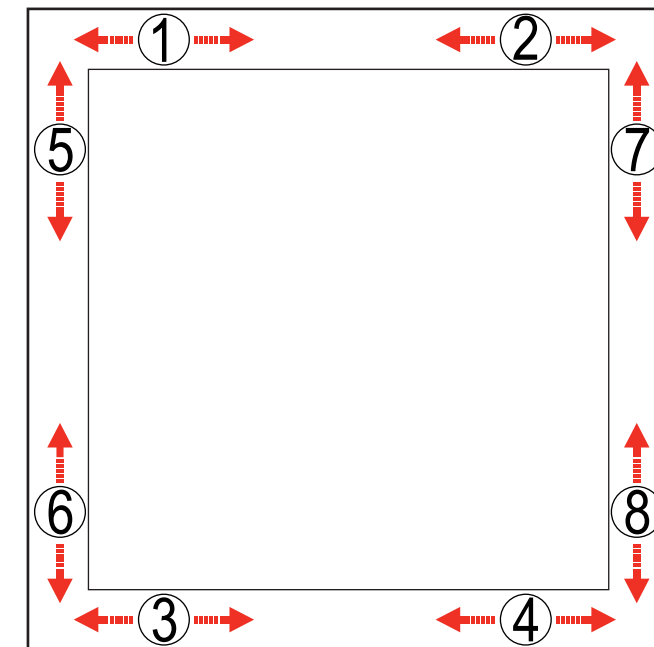

Insert narrow side of silicone welt into the channel at corner 1, with fabric to the outside.

Repeat for opposite corner 2, then corner 3, then corner 4.

Once corners are attached, press the middle of edge 1 into the channel. Then press middle of edge 2 into the channel on opposite side.

Repeat with edge 3 & 4.

Once the middle of sides are attached, fully press the silicone welt into the channel, between center and corner at location 1. Repeat the process between center and corner at location 2.

Do the same for welt on opposite side, at locations 3 & 4. Then repeat for locations 5 & 6 and 7 & 8.

Once the welt is fully inserted on all sides, smooth out edges as needed for a perfect fit.



To remove the graphic from the frame, locate the fabric **pull tab**. Gently pull on the tab to remove the graphic.

Install video:



Item	Qty.	Description
1	1	22" x 4" Base Plate
2	1	24" x 18" Base Plate
3,3A	1,1	39" CEI110 Horizontal Extrusion
4,4A	1,1	39" CEI110 Horizontal Extrusion
5,5A	1,1	39" CEI110 Horizontal Extrusion
6,6A	1,1	45" CEI110 Vertical Extrusion
7,7A	1,1	45" CEI110 Vertical Extrusion
8,8A	1,1	43.177 Z45 Vertical Extrusion

**Steps:**

Refer to the CEI110 Frame Assembly general information page.

- 1) Assemble horizontals [3-4-5], [3A-4A-5A] & verticals [6-7], [6A-7A] using straight connectors.
- 2) Attach vertical assemblies [6/7], [6A/7A] between horizontal assemblies [3/4/5], [3A/4A/5A] using corner connectors.
- 3) Assemble verticals [8-8A] between horizontals [4,4A]. See PR53 Connector and Z45 Attachment details.
- 4) Attach Base Plate [1] to horizontal [5], and Base Plate [2] to horizontal [3] using Bolts & Wing Nuts.

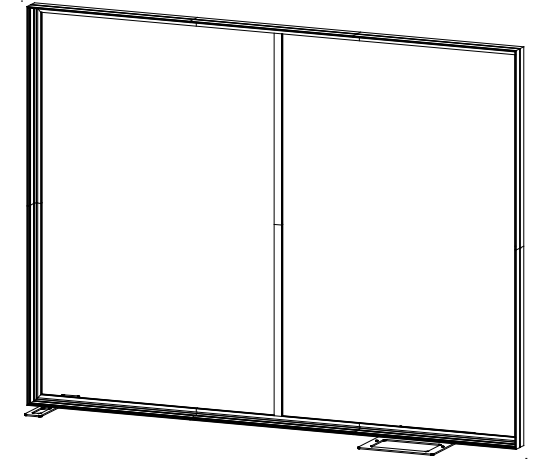

Assemble frame flat on ground.

When assembled

**\* PR53 Connector**

Insert connector into horizontal then tighten set screws to secure. Slide horizontal extrusion over connector then tighten set screw secure.

Keep all screws attached to connector after disassembling.

**\* Z45 Attachment**

Attach Z45 vertical to back groove of CEI-110 horizontal.

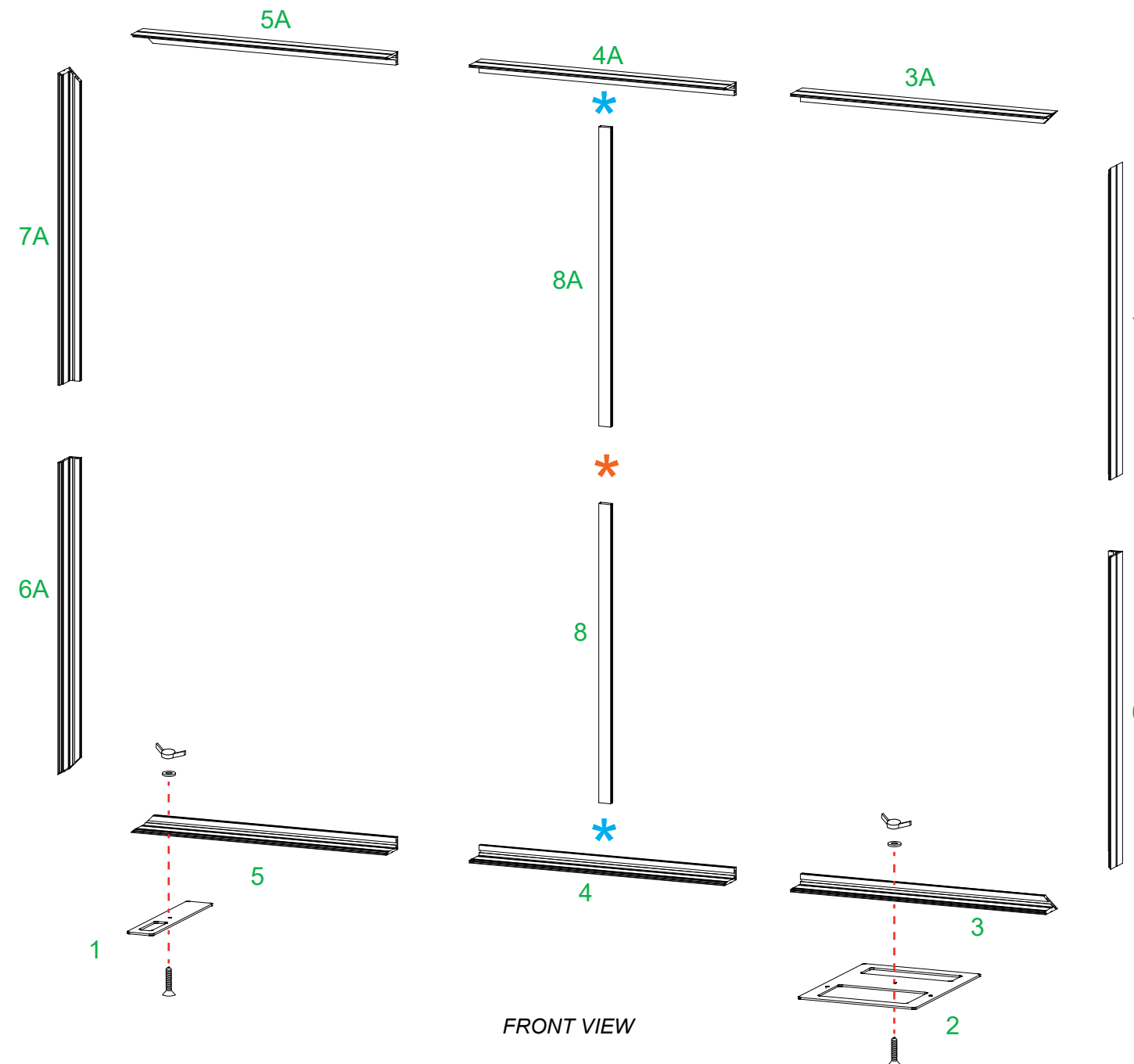

Steps:

- 1) Connect power cords to Supernova lights as shown.
- 2) Apply SEG Graphic to front of lightbox. Refer to the SEG Installation general information page.

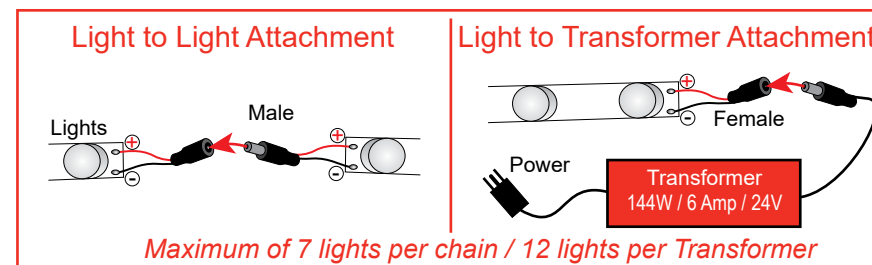
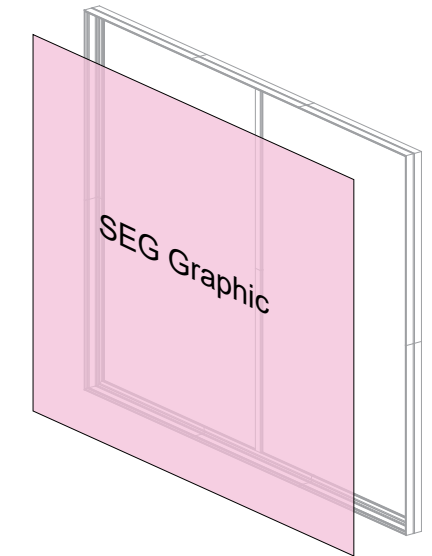
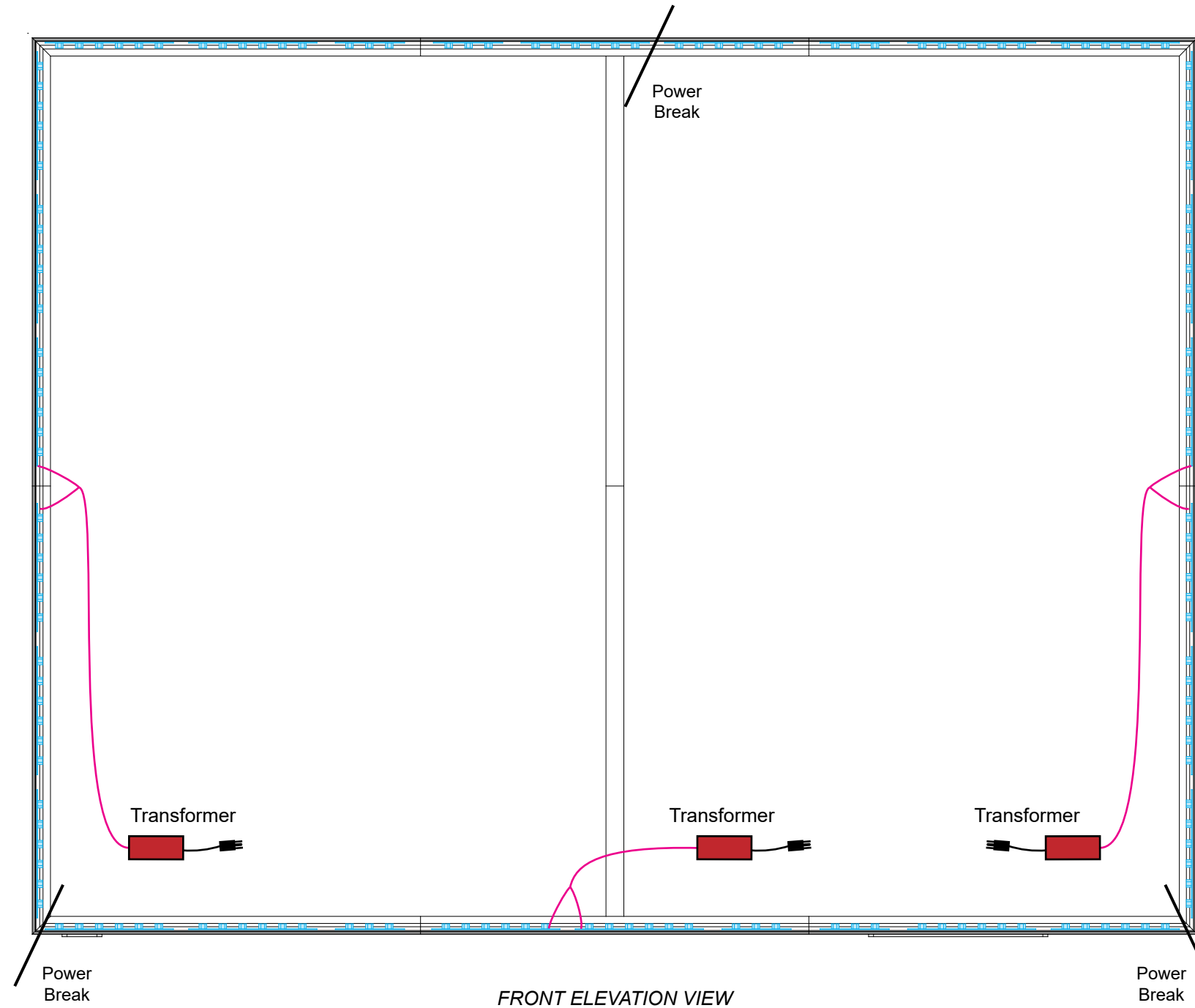

Item	Qty.	Description
9	2	48" S44 Vertical Extrusion
10	2	48" S44 Vertical Extrusion
11	4	14" Z33 Horizontal Extrusion
12	2	4" S44 Horizontal Extrusion
13	2	6" S44 Vertical Extrusion

**Steps:**

- 1) Connect verticals [9] to Base Plate [2], using bolts.
- 2) Assemble verticals [9-10]. See **Extrusion Connector** detail.
- 3) Attach horizontal [11] between [9/10], then slide **infill** between [9/10].  
Repeat step two more times.
- 4) Connect verticals [13] to horizontal [3A].
- 5) Attach horizontals [12] between verticals [10] and [13].

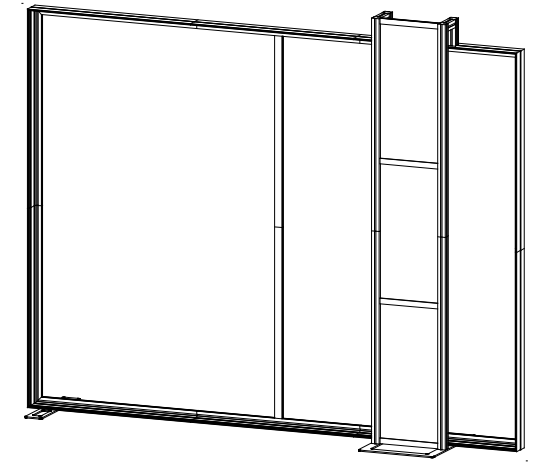

When assembled

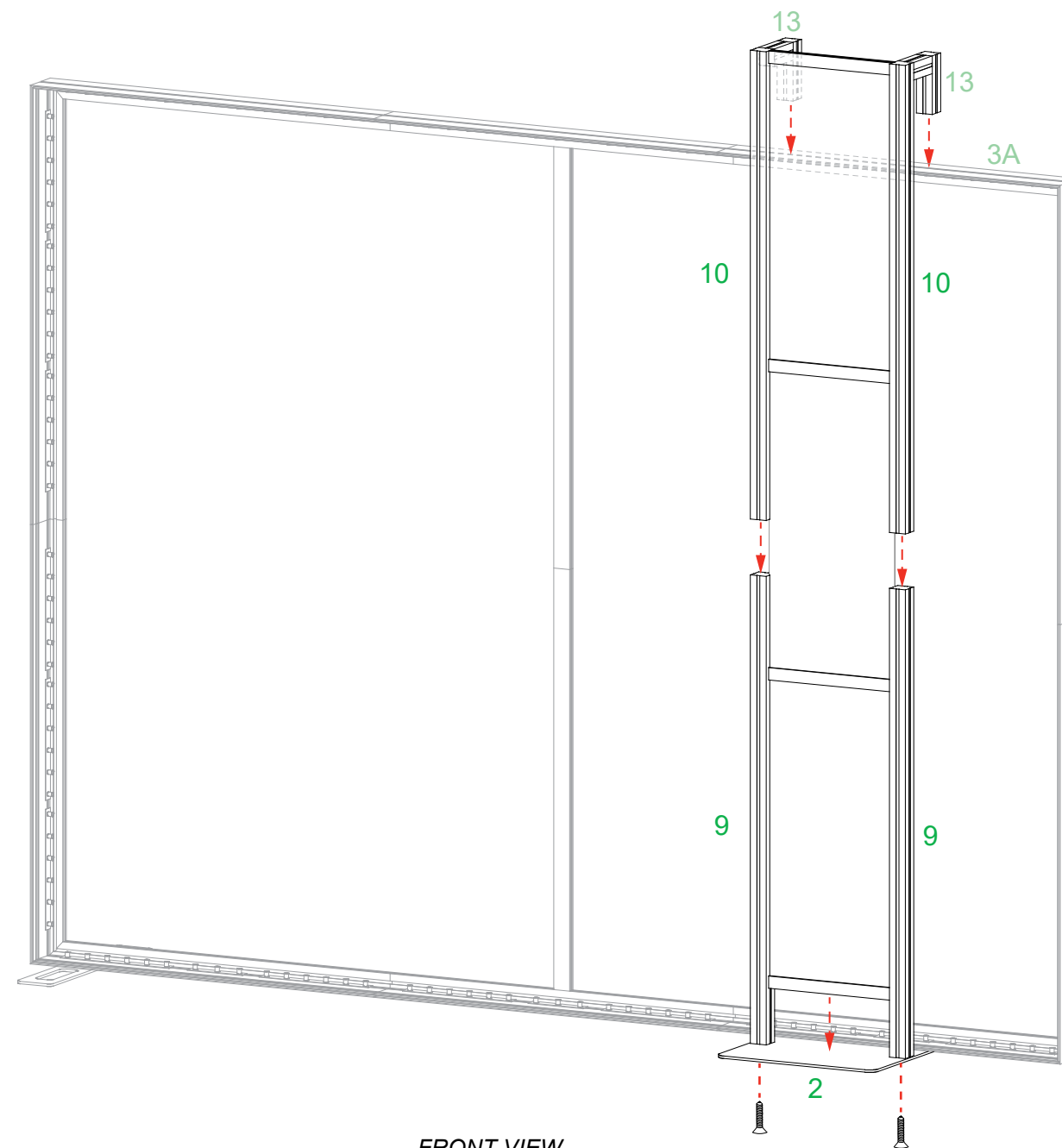
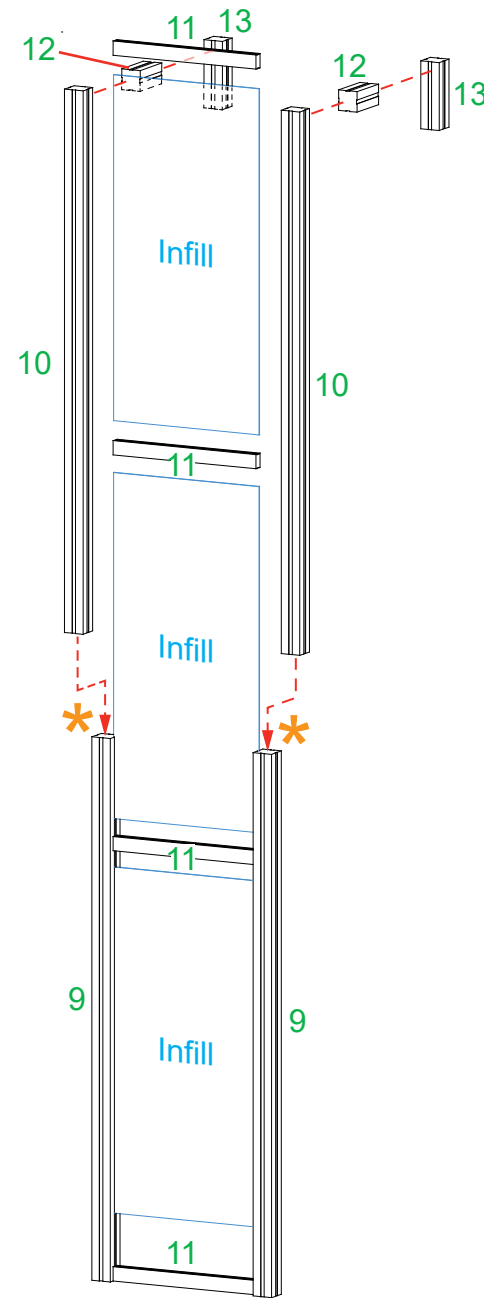

FRONT VIEW

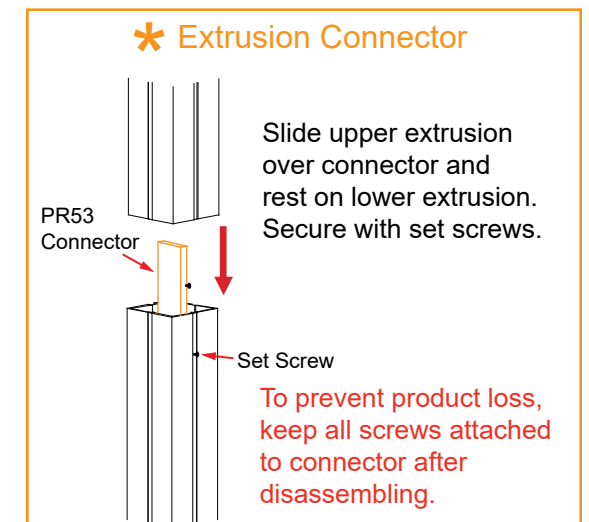

Item	Qty.	Description
--	4	Backwall Shelf w/ Z32 extrusion
--	1	Large Monitor Mount

- Steps:
- 1) Install Monitor Mount to vertical assemblies [9/10].  
See **Monitor Mount Attachment** detail.
  - 2) Attach Shelves to vertical assemblies [9/10].  
See **Shelf Attachment** detail.

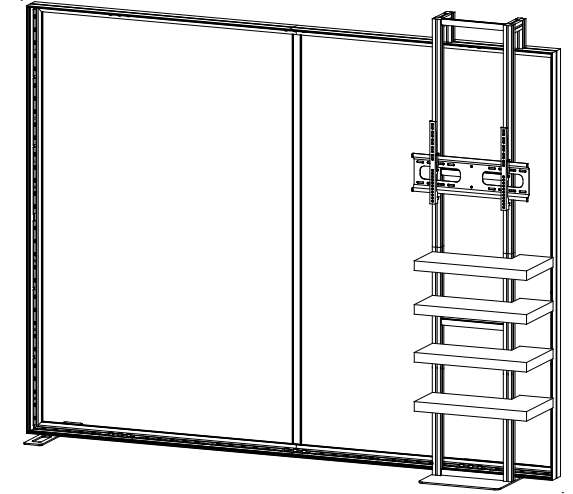

When assembled

**\* Monitor Mount Attachment**

Slide V4 connectors into vertical channel of extrusions. Tighten set screws to secure.

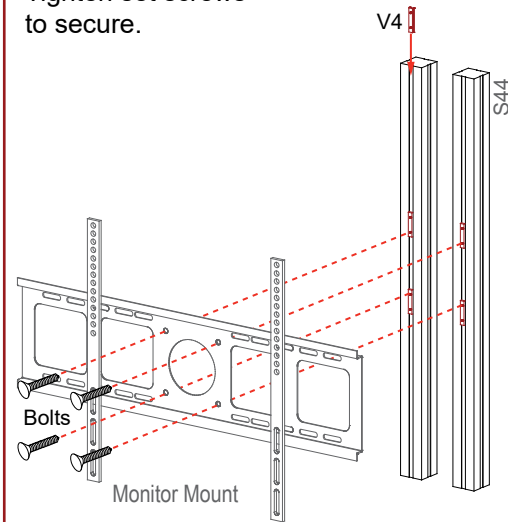
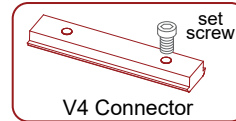

Attach Monitor Mount to V4 Connectors, using bolts.

**Shelf Attachment**

Insert locks into groove of vertical extrusion & tighten setscrews.

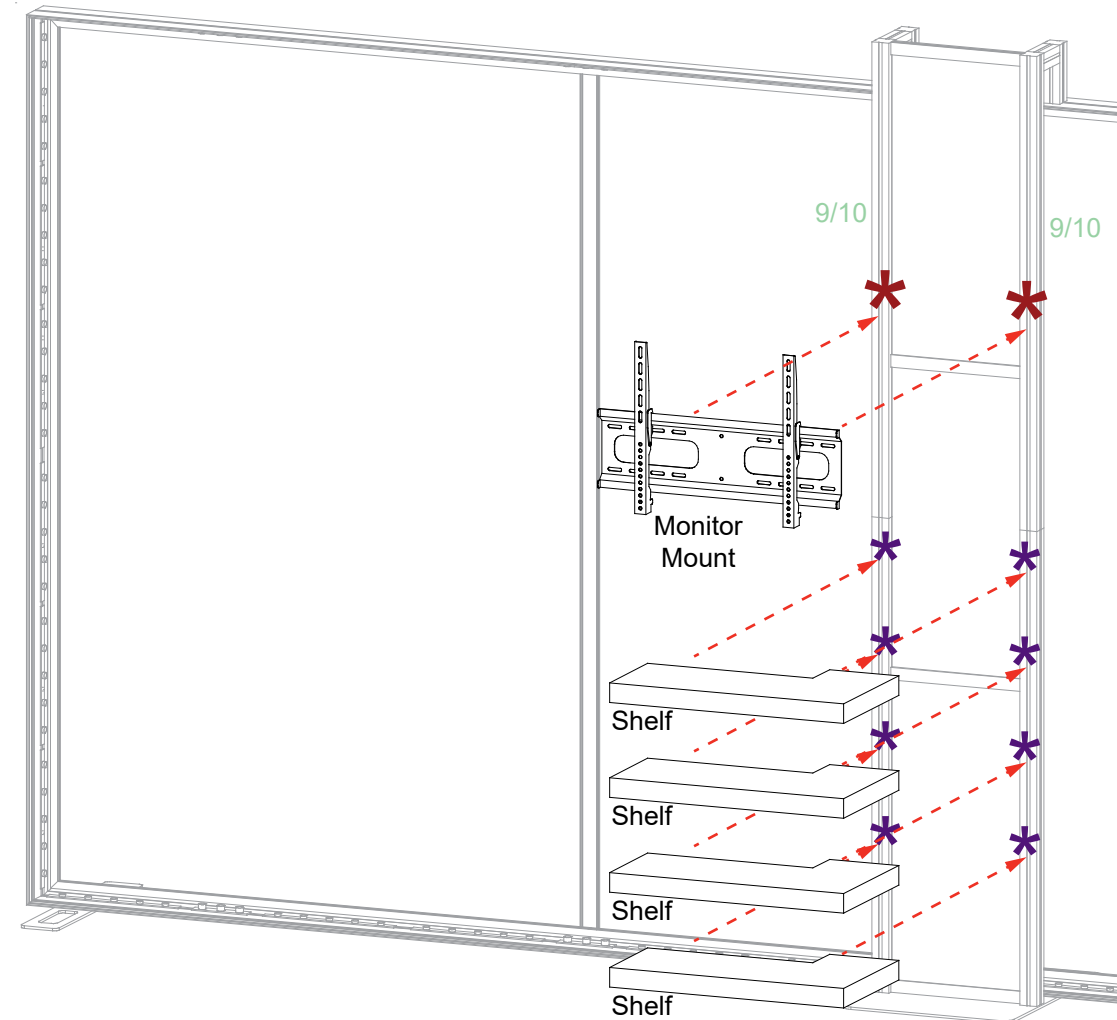
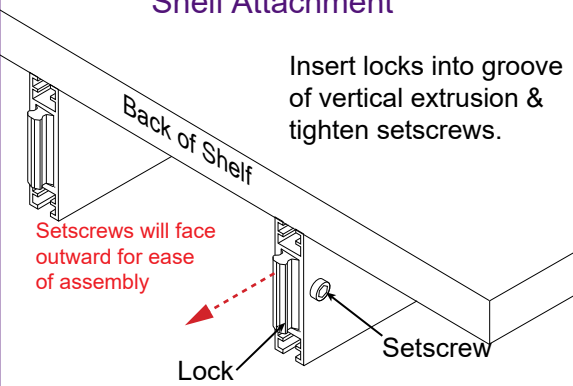

FRONT VIEW

CRATE PACKING