

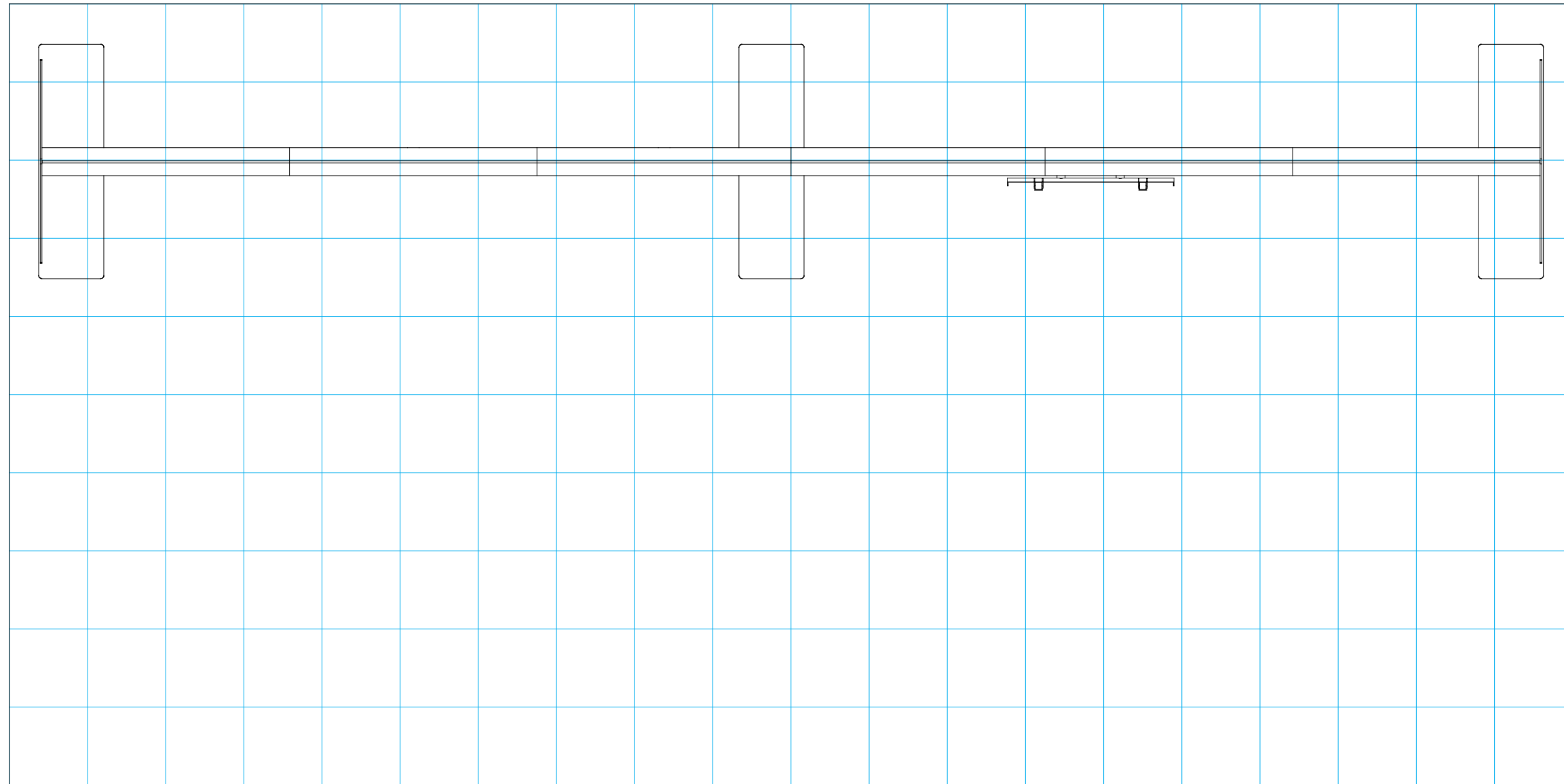

SETUP INSTRUCTIONS



 = 1 sq foot

General Setup Instructions

- Read entire setup instruction manual prior to unpacking parts and pieces.
- The setup instructions are created specifically for this configuration.
- Setup instructions are laid out sequentially in steps, including exploded views with detailed explanation for assembly.

Cleaning & Packing

- For Cleaning Metal, Plex, & Laminate Parts: Use a **MILD NON-ABRASIVE** cleanser and soft cloth/paper towel to clean all surfaces.
- Keep exhibit components away from heat and prolonged sun exposure. **Heat and UV exposure will warp and fade components.**
- Retain all provided Packing Materials. All provided packing materials are for ease of repacking & component protection.

Disassembly

- For loss prevention, tighten all set screws and locks during disassembly.

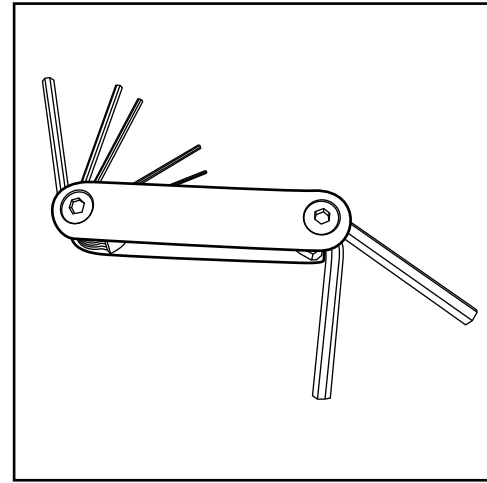

Hex Tool - Essential for Assembly

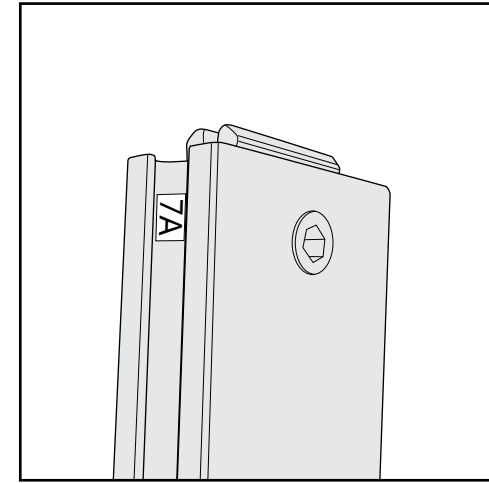

Part Identification - Numbering

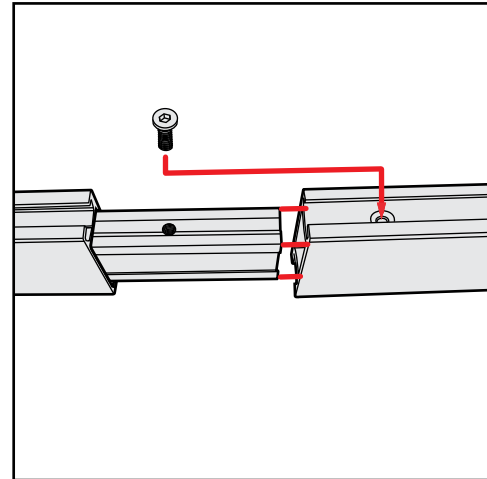

Spline Connection

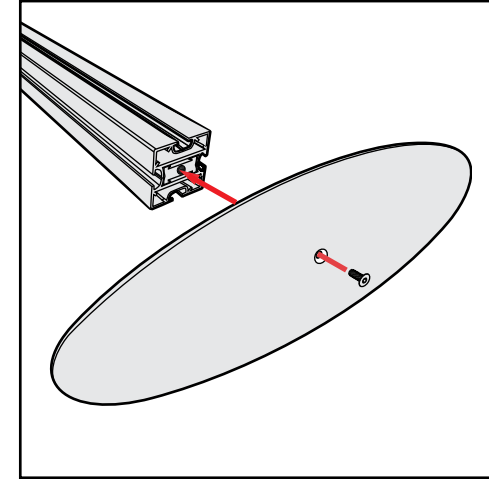

Base Plate & Extrusion Connection

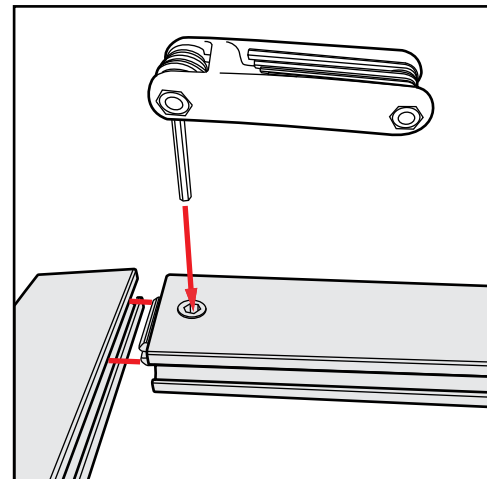

Extrusion & Lock Connection

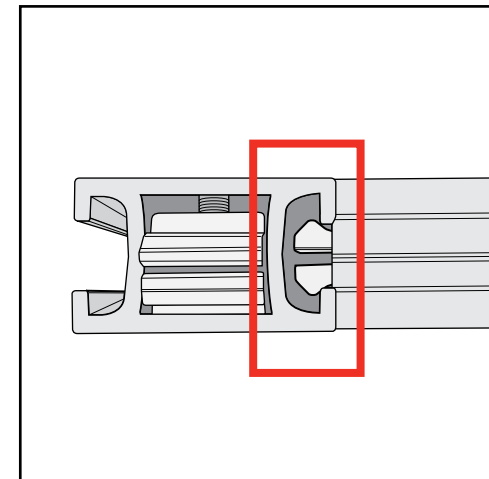

Engaged Lock



WARNING



DO NOT USE POWER TOOLS

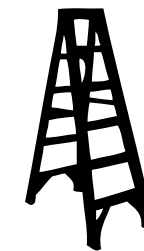

LADDERS OR LIFTS
MAY BE REQUIRED



ALL CONNECTIONS MUST
BE TIGHTLY SECURED

Straight Connection

When assembling frame, first attach all **straight connectors**, then attach **corner connectors**.

- 1) Place extrusions end-to-end.
- 2) Loosen all knobs, then slide **straight connectors** across the seam of extrusions.
- 3) Tighten all knobs to secure connection.

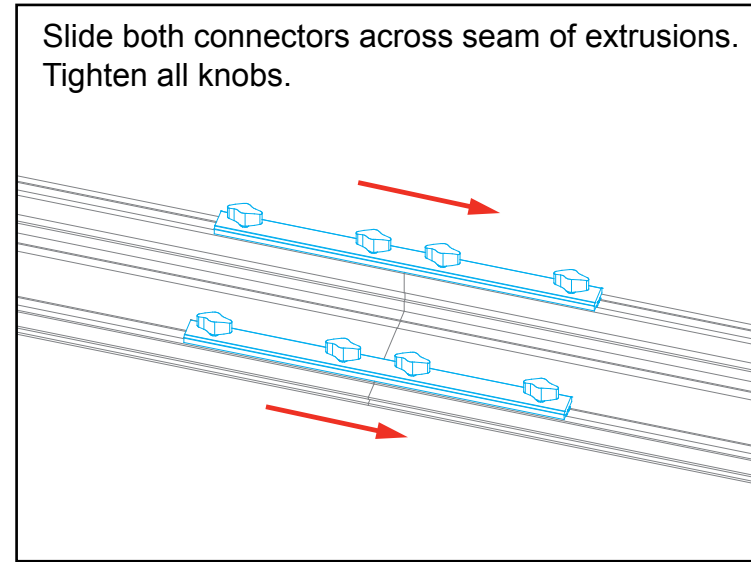
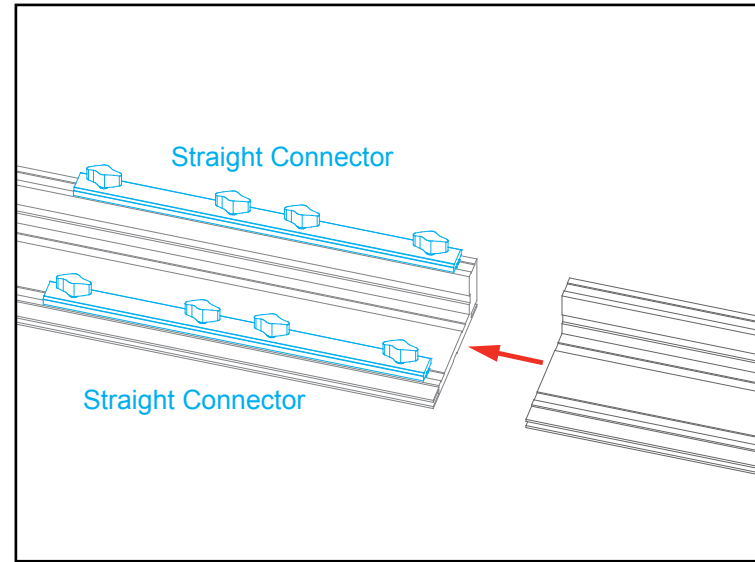

All knobs must be tightened securely to ensure a proper connection.

Disassembly

- 1) Loosen all knobs.
- 2) Slide connectors off of one extrusion.
- 3) Tighten knobs to prevent loss during packing & shipping.

Keep straight connectors in groove of extrusion. Do not remove connectors during disassembly.

Corner Connection

- 1) Loosen knobs, then slide vertical extrusions onto **corner connectors** of **lower** horizontal extrusion.
- 2) Slide **corner connectors** of **upper** horizontal extrusion into grooves of vertical extrusions.
- 3) Tighten all knobs to secure connection.

Disassembly

- 1) Loosen knobs on vertical extrusions.
- 2) Slide the vertical extrusions off of **corner connectors** on lower and upper horizontal extrusions.

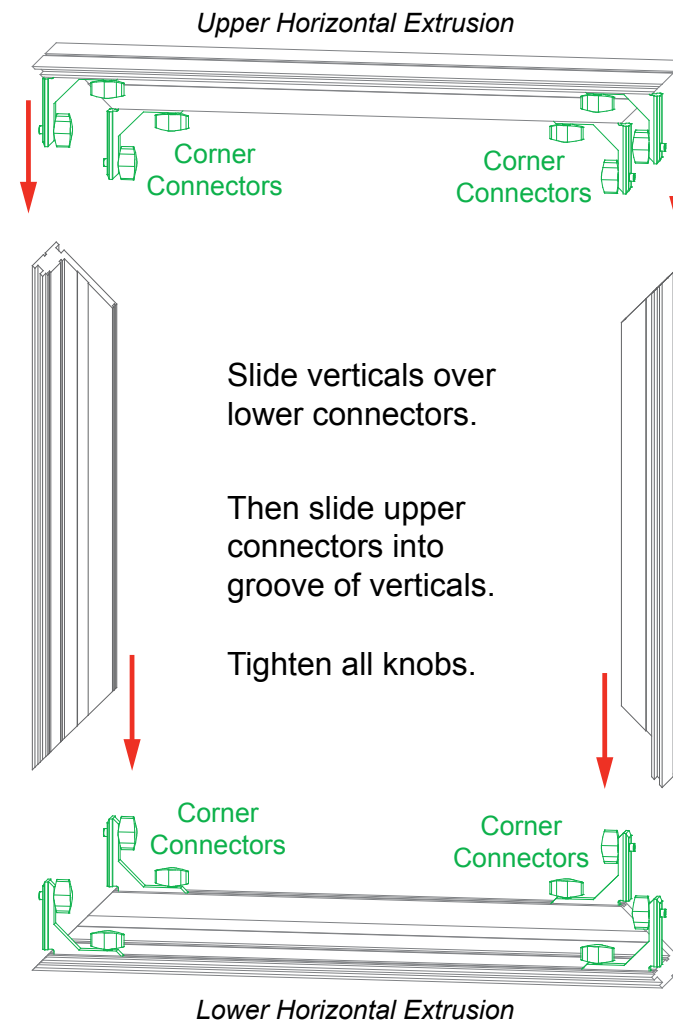

Adjust connectors if necessary to prevent gaps in connection.

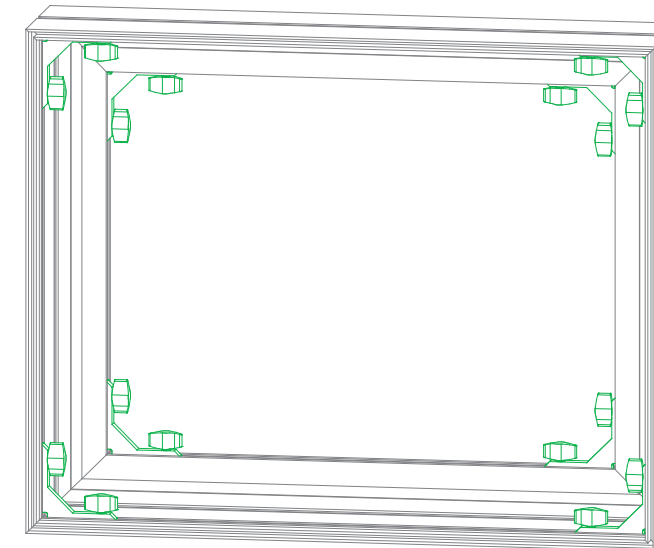

COMPLETED ASSEMBLY

All knobs must be tightened securely to ensure a proper connection.

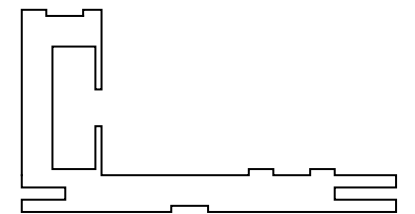

CEI110 Profile

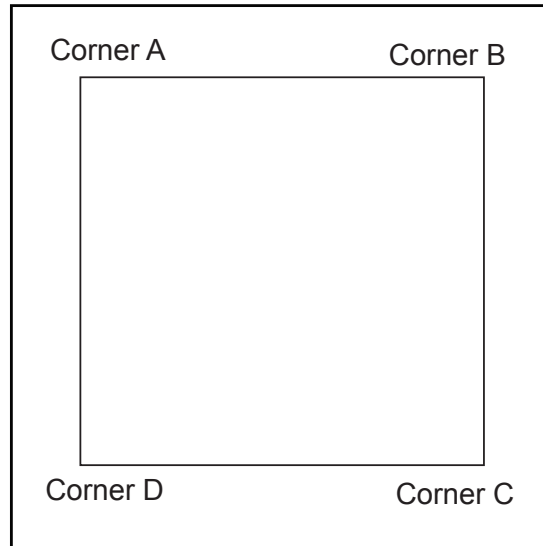

It is important to first insert graphic into each alternate corner then to the sides of the frame. If this is not done, graphic will not fit into the frame correctly.

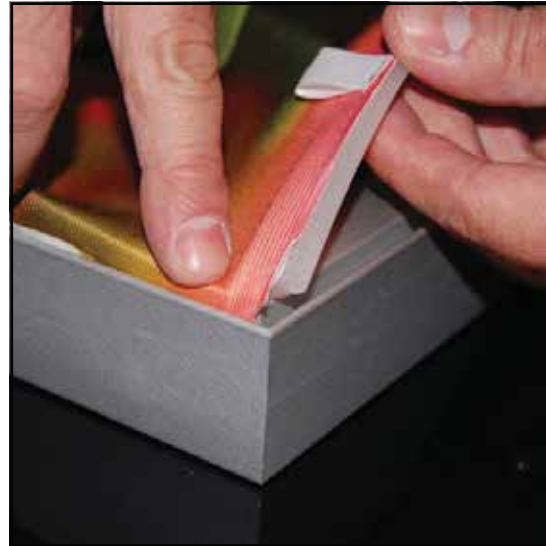

Step 1
Insert corner A. Turn edge of graphic so silicon welt is perpendicular to face of graphic. Insert narrow side of welt with fabric to outside into the channel. Repeat for other side of this corner.

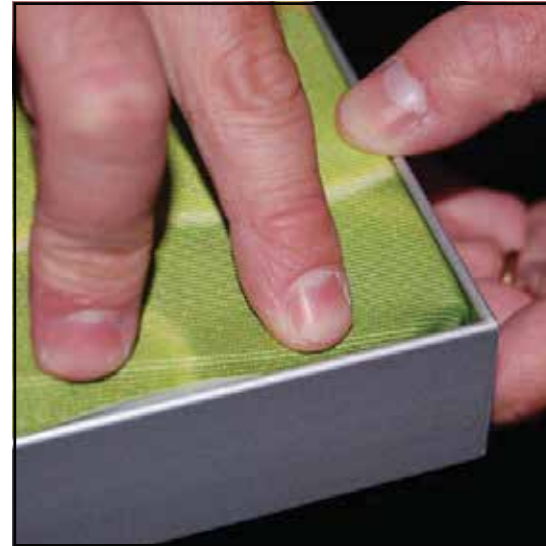

Step 2
Repeat Step 1 for opposite corner C, then insert corner B, followed by corner D, to complete the installation of the corners.



Step 3
Once all corners are inserted, press one silicon edge into channel from corners and work toward the center. Make sure welt is fully inserted into channel. Continue until all sides are done. Smooth out edges of graphic.

Graphic Removal

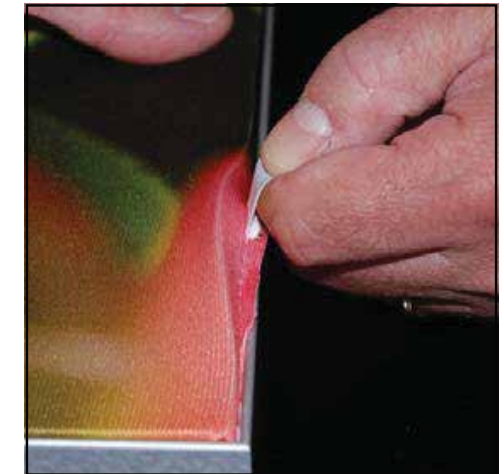

To remove the graphic from the frame, locate the fabric pull tab. Gently pull up on the tab to remove the fabric.

Top View of Each Level

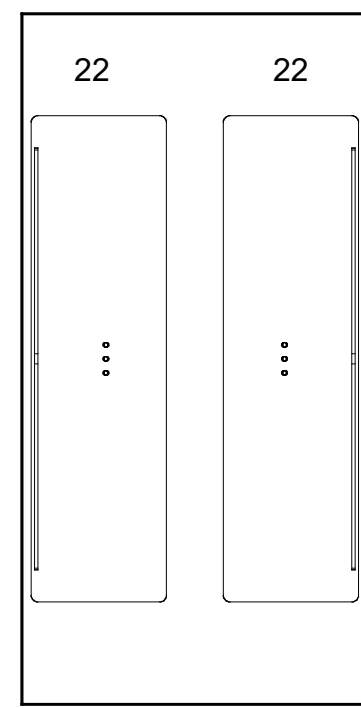

Level 1
(Bottom level)

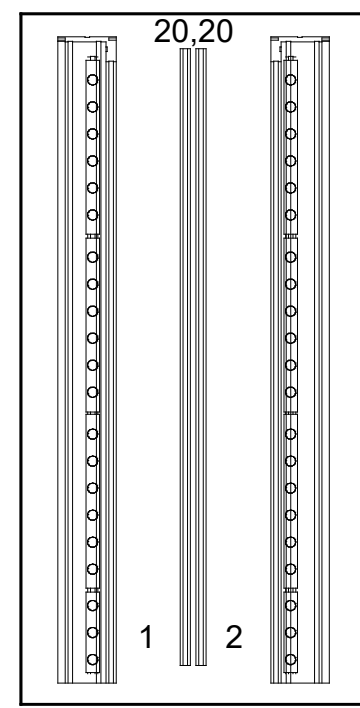

Level 2

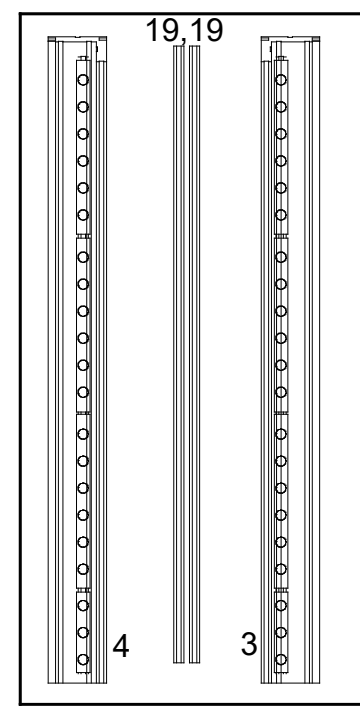

Level 3

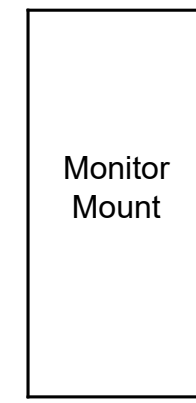

Top View of Each Level

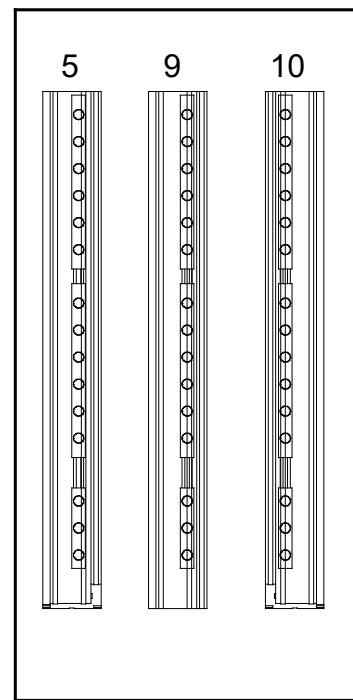

Level 1
(Bottom level)

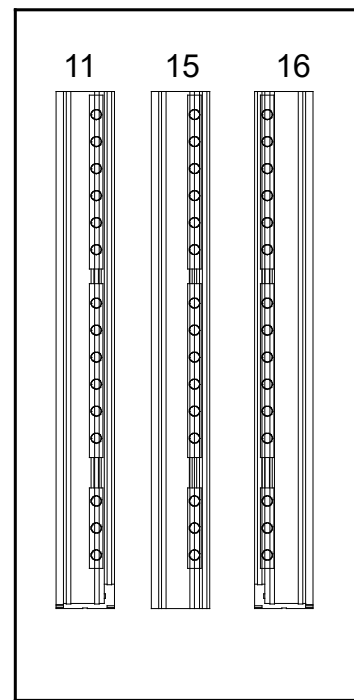

Level 2

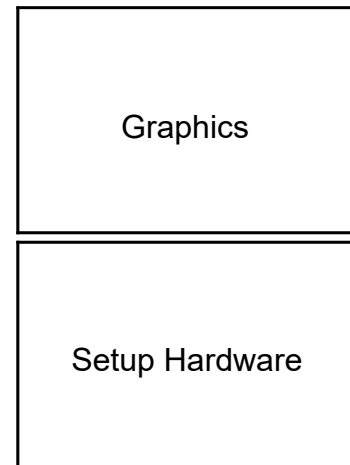

Top View of Each Level

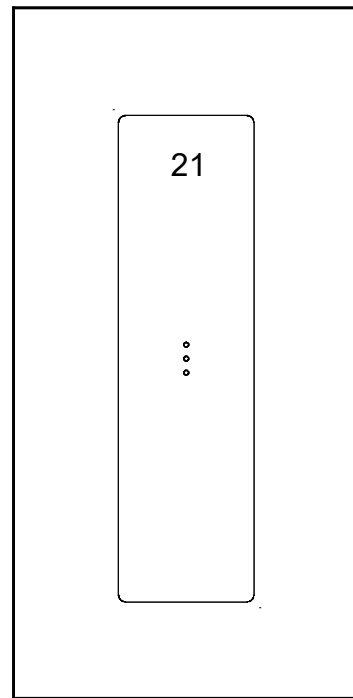

Level 1
(Bottom level)

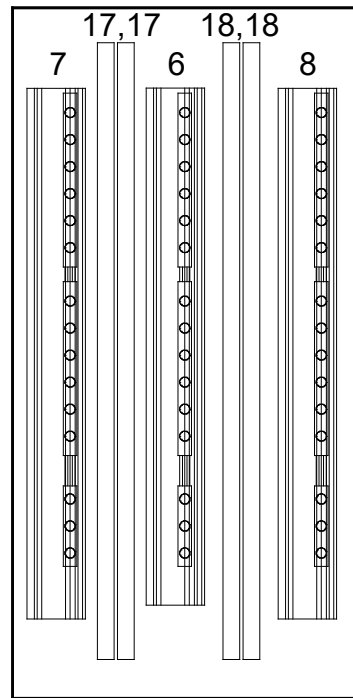

Level 2

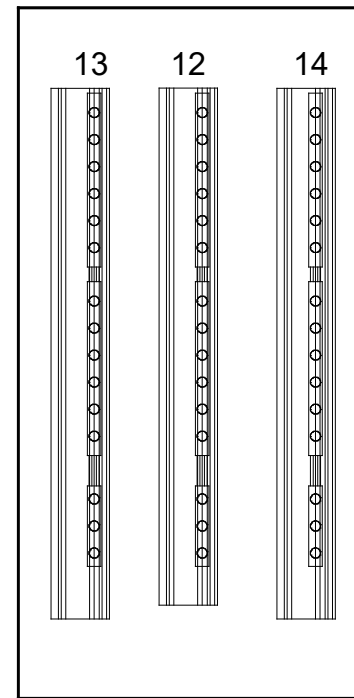

Level 3

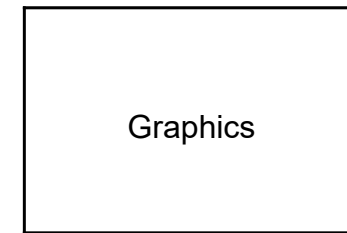

Item	Qty.	Description
1	1	47.5"h CEI110 Vertical Extrusion
2	1	47.5"h CEI110 Vertical Extrusion
3	1	47.5"h CEI110 Vertical Extrusion
4	1	47.5"h CEI110 Vertical Extrusion
5	1	38"w CEI110 Horizontal Extrusion
6	1	38"w CEI110 Horizontal Extrusion
7	1	39"w CEI110 Horizontal Extrusion
8	1	39"w CEI110 Horizontal Extrusion
9	1	38"w CEI110 Horizontal Extrusion
10	1	38"w CEI110 Horizontal Extrusion
11	1	38"w CEI110 Horizontal Extrusion
12	1	38"w CEI110 Horizontal Extrusion
13	1	39"w CEI110 Horizontal Extrusion
14	1	39"w CEI110 Horizontal Extrusion
15	1	38"w CEI110 Horizontal Extrusion
16	1	38"w CEI110 Horizontal Extrusion
17	2	45.667" Z45 Vertical Extrusion
18	2	45.667" Z45 Vertical Extrusion
19	2	45.667" Z45 Vertical Extrusion
20	2	45.667" Z45 Vertical Extrusion w/ holes
21	1	30" x 10" Base Plate
22	2	Corner Base Plate

Steps:

Note: Refer to the CEI110 Frame Assembly general information page.

- 1) Assemble verticals [1-2], [3-4] & horizontals [5-6-7-8-9-10], [11-12-13-14-15-16] using straight connectors.
- 2) Connect vertical assemblies [1/2], [3/4] between horizontal assemblies, using corner connectors.
- 3) Attach verticals [17-18], [19-20] between horizontal assemblies as shown. See **Z45 Attachment** detail.
- 3) Connect Base Plate [21] to bottom horizontals, using bolts.
- 4) Install Corner Base Plates [22].
See **Corner Base Plate Attachment** detail.

Assemble frame flat on ground.

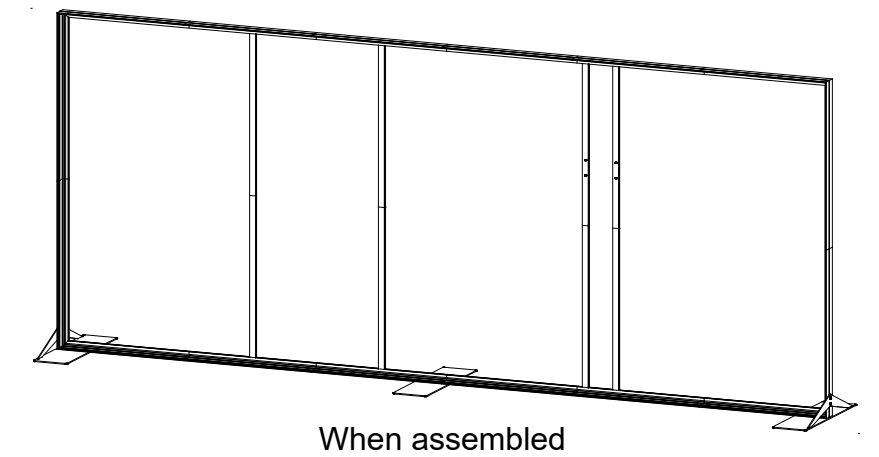

When assembled

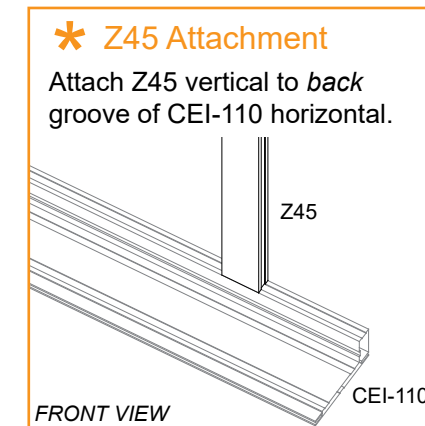
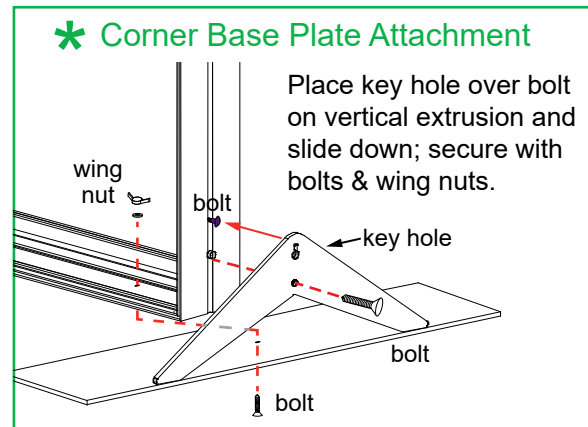
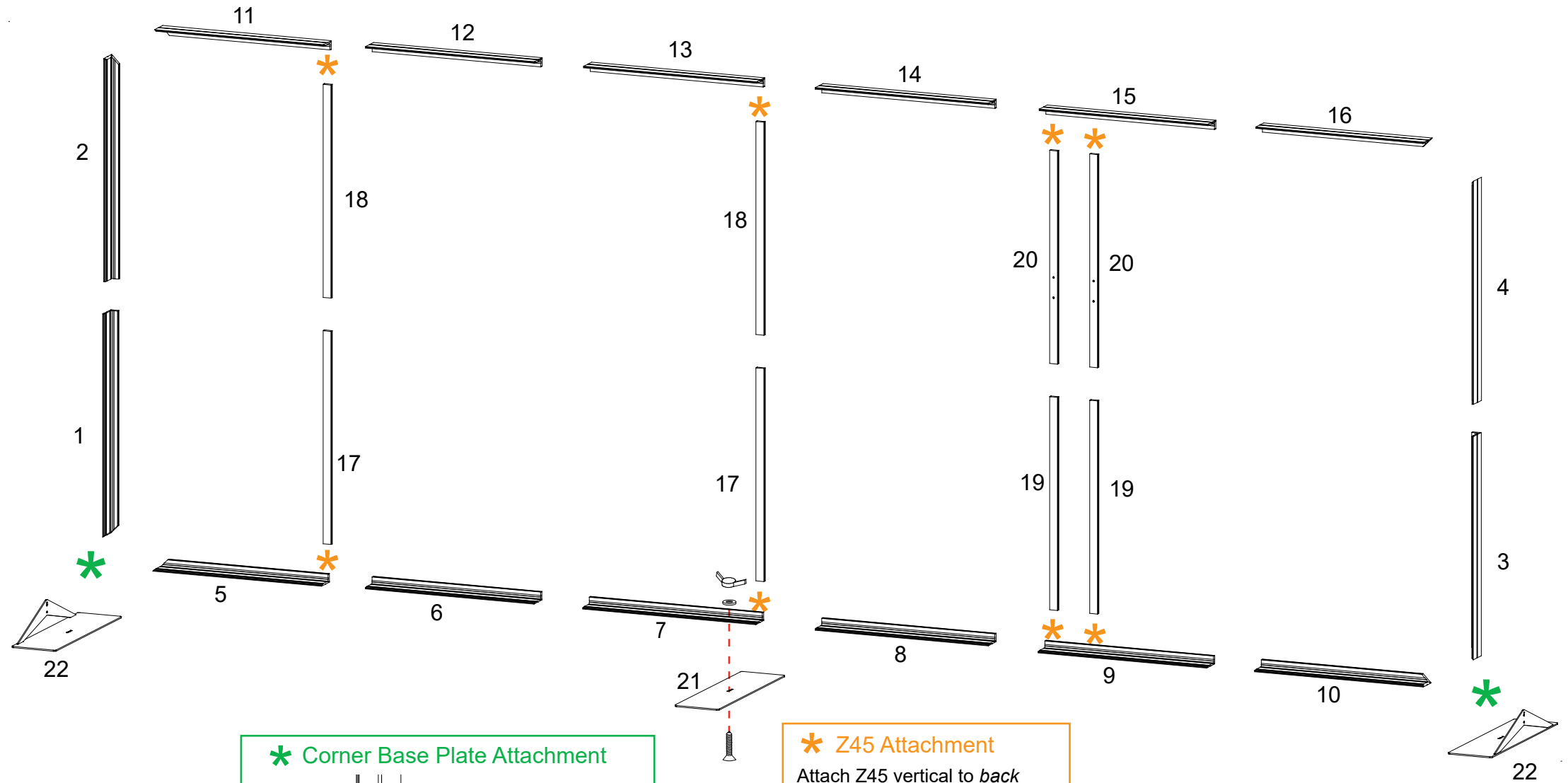

Steps:
1) Connect power cords to Supernova lights, as shown.

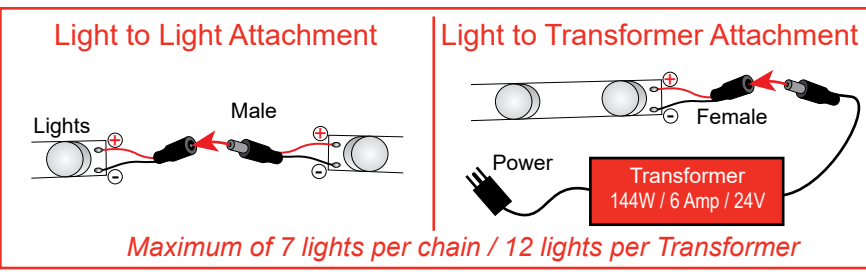
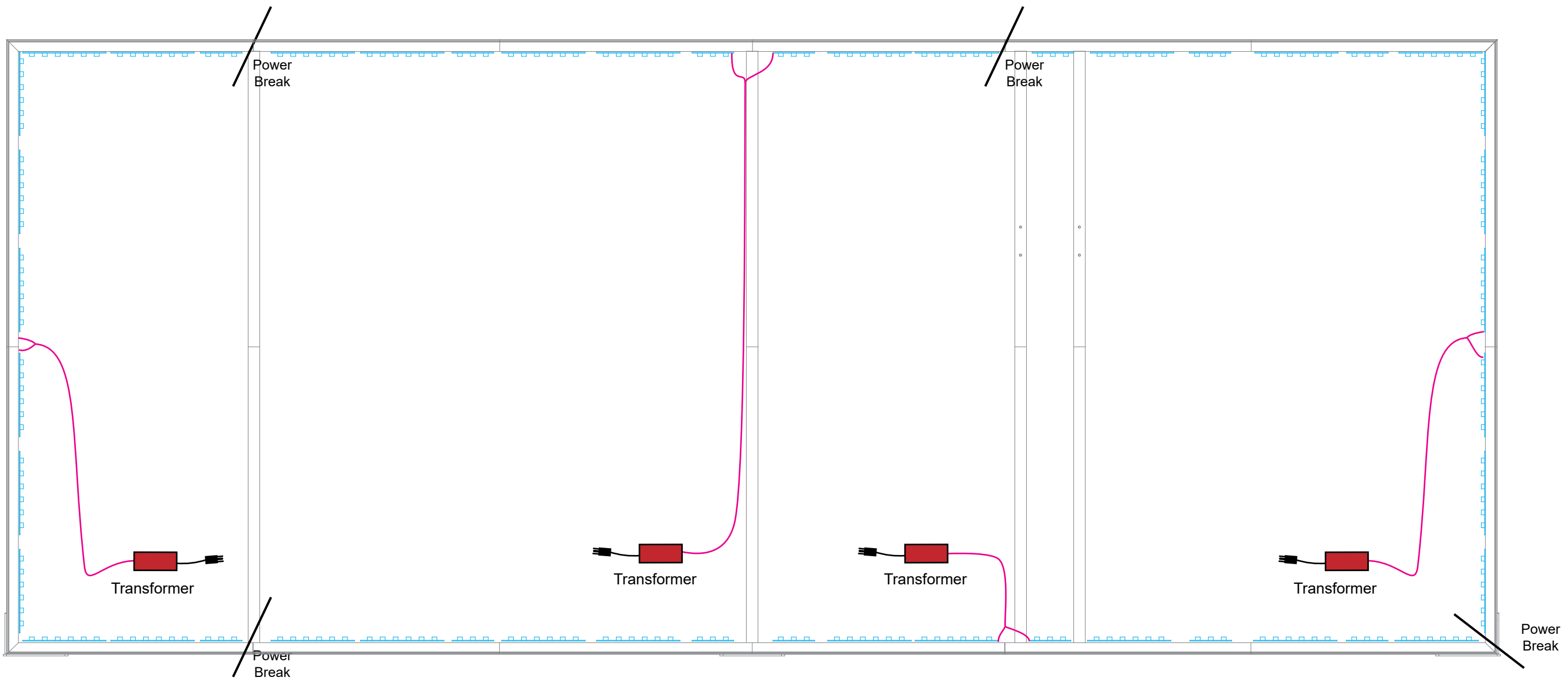

Steps:

Refer to the *SEG Installation general information page*.

- 1) Apply SEG Graphic to front of lightbox assembly.
- 2) Attach Monitor Mount to verticals [17/18]. See [Monitor Mount Attachment](#) detail.
- 3) Apply SEG Blocker to back of lightbox assembly.

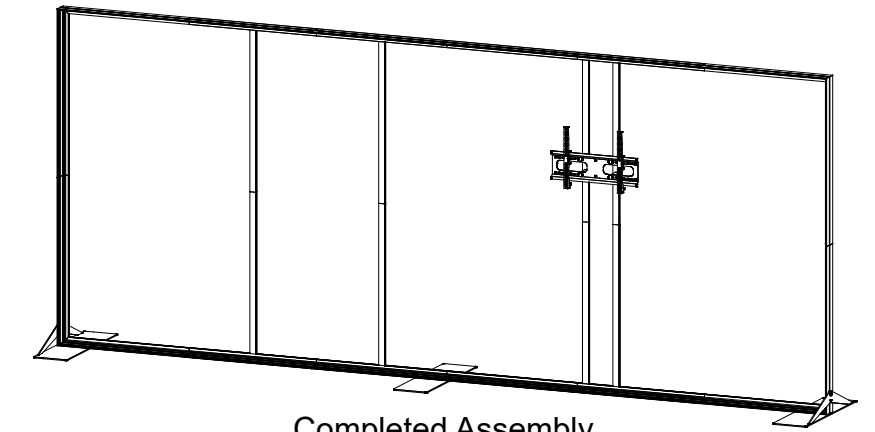

*** Monitor Mount Attachment**
 Attach Stand-off barrels to Z45 extrusions using bolts.

Connect Monitor Mount to Standoff Barrels using Bolts.

Note: Monitor mounts install through SEG graphic.

